



Submersible Solid Handling Pumps

Model SL

These vortex type (2-pole motor) submersible pumps are higher efficiency, higher head which feature low life-cycle costs and easy maintenance.



Applications:

- Sewage Lift Stations
- Treated Sewage System
- Waste Water Transfer
- Dewatering
- General Industrial Service

ISO 9001 Certificate



EIM ELECTRIC CO., LTD.

With over 50 years of proven experience in the design and the difficult applications of heavy duty submersible pumps handling sewage, solids, sludge and slurries, EIM has been providing pumping solutions which permit customers to continuously improve pumping system reliability and cost efficient performance. The SL series pumps with vortex impeller have proven successful operation in the toughest applications handling large solids and stringy material.

GENERAL DESCRIPTION

| | Standard | Option |
|-------------------------------------|---|--|
| Pump | Free Standing Models | Guide Rail System |
| Discharge Diameter | 50 and 80 mm | |
| Flow and TDH | See performance curves on the back page. | |
| Impeller | Vortex impeller | |
| Max. Solids Size | 46 mm sphere | |
| Max. Submergence | 20 m | |
| Liquid Temperature | -10 °C to 40 °C | High temperature designs up to 80° C. |
| Materials | | |
| Impeller/Pump Casing /Suction Cover | Cast Iron | |
| Hardware | 304 Stainless Steel | |
| Motor | | |
| Configuration | Flange mounted, air-filled submersible vertical AC motor | |
| Synchronous Speed | 3000RPM (50Hz)/3600RPM (60Hz) | |
| Insulation Class / SF | F / 1.15 | Insulation Class H |
| Voltages / Phase / Hertz | 200, 380, 400 Volts / 3φ/ 50 Hz 220, 380, 440 Volts / 3φ/ 60 Hz | Special voltages in the range of 200-600 Volts |
| Thermal Protection Device | Bimetallic over current switch | |
| Cable Length | 10 m | Extra length cable |
| Materials | | |
| Motor Housing | Cast Iron | |
| Motor Shaft | 403 Stainless Steel | |
| Shaft Seals | Double shaft seals [Outer seal (process side)] Silicon Carbide faces (both rotating and stationary faces) [Inner seal (motor side)] Carbon against Ceramic faces | Silicon Carbide faces (both rotating and stationary faces) inner and outer seals and VITON seal elastomers |
| Bearings | Deep groove ball bearings | |
| O-Rings | Nitrile Butadiene Rubber (NBR) | VITON O-Rings |

AVAILABLE MODELS

| Discharge Diameter (mm) | Model No. | | BHP | | Solid Handling mm |
|-------------------------|---------------|-------------------|------|-----|-------------------|
| | Free Standing | Guide Rail System | KW | HP | |
| 50 | SL-51E | SL-51B1 | 0.75 | 1 | 32 |
| 80 | SL-82E | SL-82BH | 1.5 | 2 | 42 |
| | SL-83E | SL-83BH | 2.2 | 3 | 42 |
| | SL-85E | SL-85BH | 3.7 | 5 | 42 |
| | SL-88E | SL-88BH | 5.5 | 7.5 | 46 |
| | SL-810E | SL-810BH | 7.5 | 10 | 46 |

FEATURES

① CABLE

Extra hard usage, water-resistant vinyl cable is used for electric cable.

② CABLE ENTRY

Strain relief rubber bushing integrated with cable sheath at the entry point is tightly compressed to the motor housing cover. In addition, each cable strand at the entry point is formed into a solid conductor for a true non-wicking cable entry. This double sealing system completely prevents water from entering into the motor housing.

③ LIFTING DEVICE

Lifting eye-bolts of 304 stainless steel are of adequate strength to lift the entire pump assembly.

④ MOTOR

An air-filled, induction motor with specially treated class F (155° C) nonhygroscopic insulation and rated with 1.15 service factor is used as standard. The motor housing of heavy duty cast iron is sealed using O-rings.

⑤ SHAFT

The high quality, one-piece, oversized shaft made of 403 stainless steel is designed so as to lengthen bearing and seal life reducing shaft deflection and vibration.

⑥ BEARINGS

Both main and support bearings packed with lithium grease for high temperature usage consist of oversized deep groove ball bearings, countering both radial and axial forces.

⑦ SHAFT SEAL

Double mechanical seal system for maximum resistance to corrosion, abrasion and thermal shock prevents water from penetrating into the oil chamber and the motor housing. The outer seal (process side) uses Silicon Carbide faces (both rotating and stationary faces). Carbon against ceramic faces are used for the inner seal (motor side). In addition, to prevent dust, sand, mud, sludge, slurry, etc. from entering into the seal area, the dust seal is mounted on the outside of the shaft seal, facing to process liquid.

⑧ OIL CHAMBER

Oil in the oil chamber lubricates and cools the shaft seals and functions as a buffer to prevent water penetration into the motor.

⑨ PUMP CASING

Owing to the specially designed pump casing with large opening at motor side, motor unit and wet end are easily separated for fast access to impeller and shaft seals. This results in true savings, greatly reducing maintenance and downtime costs.

⑩ IMPELLER

Vortex impeller is possible to handle raw sewage containing large solids and stringy material along with high pump efficiency.

⑪ THERMAL PROTECTOR

To protect over heating, bimetallic over current switch is built in the motor housing cover.

⑫ HARDWARE

All the external hardware are made of heavy duty 304 stainless steel.

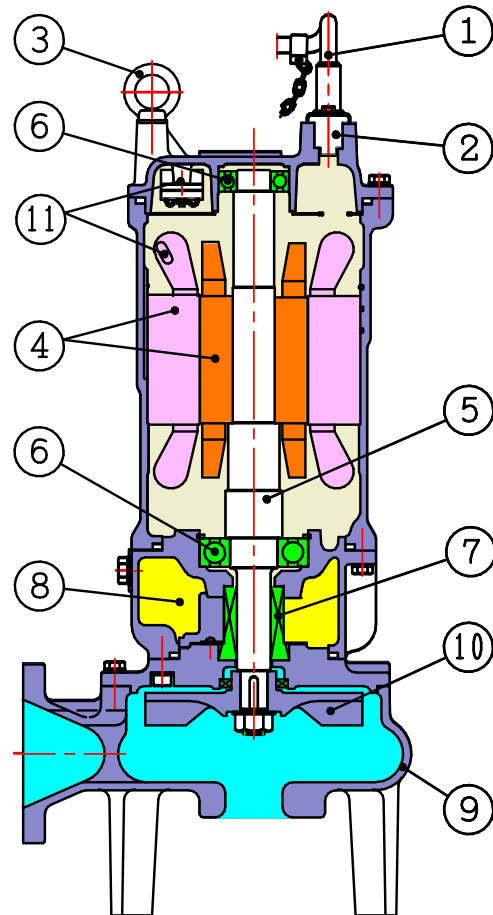

PUMP PERFORMANCE CURVES

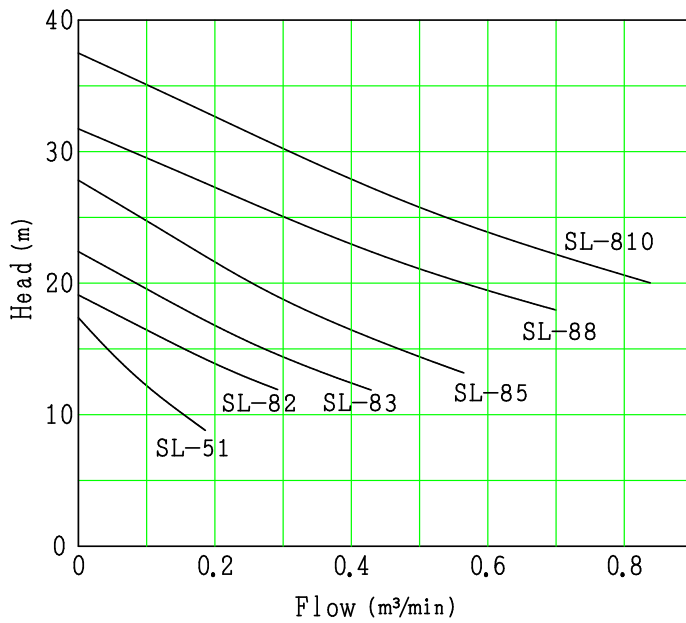

DIMENSIONS

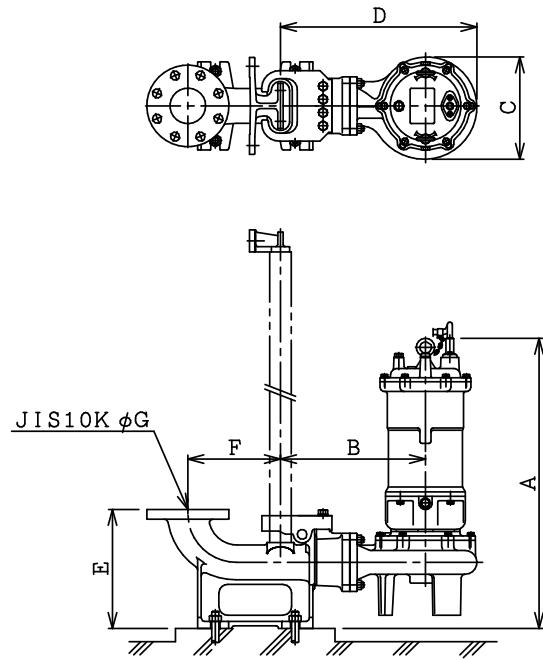

(All dimensions in mm)

| Discharge Diameter | Model | A | B | | C | | D | | E | F | G | w/t (kg) | |
|--------------------|----------|-----|------|------|------|------|------|------|-----|-----|----|----------|-----------------|
| | | | 50Hz | 60Hz | 50Hz | 60Hz | 50Hz | 60Hz | | | | Pump | Discharge Elbow |
| 50 | SL-51B1 | 460 | 216 | | 190 | | 310 | | 210 | 125 | 50 | 30 | 13 |
| 80 | SL-82BH | 660 | 327 | | 235 | | 445 | | 270 | 209 | 80 | 60 | 25 |
| | SL-83BH | 660 | 327 | | 235 | | 445 | | | | | 65 | |
| | SL-85BH | 660 | 327 | | 235 | | 445 | | | | | 70 | |
| | SL-88BH | 835 | 367 | | 305 | | 520 | | | | | 130 | |
| | SL-810BH | 835 | 367 | | 305 | | 520 | | | | | 140 | |



SAFETY PRECAUTIONS

- Before operating our pumps, read the operation manual carefully.
- All the pictures shown in this catalog have been taken after removing all the safety devices legally required, to make the products easier to see.
- Pump and pump installations drawings are only for explanatory and descriptive purposes.

• The designs or Specifications of the models in this catalogue are subject to change without prior notice due to continual improvement.

EIM ELECTRIC CO., LTD.

URL <http://www.eimpump.co.jp>

412, Katsushika 2-chome, Funabashi City, Chiba, 273-0032 Japan
Phone: +81-47-437-2711 Telefax: +81-47-437-3969

PCE-2018
Printed in Japan June 2009